

TRITON/DUAL

New and improved powered, height adjustable, tilt-in-space shower commode chair

With its compact footprint, Triton/Dual is ideally suited for use in small bathrooms. It is an indispensable assistive technical aid in the care environment.

An optimal solution for one-to-one transfers (one caregiver assisting one patient).



Better working environment and more comfort

- Correct working posture eliminates strain and stress on the caregiver's back, shoulders and knees.
- With the electrical seat tilt and adjustable backrest, Triton Dual makes it easy for the user to find the most comfortable sitting position.
- The lift height of 40 cm helps both the caregiver and the user.
- The height adjustment allows an optimal positioning of the chair, ensuring a correct working posture for the care giver.
- For the user, the height adjustment means increased independence; it is possible to adjust the chair, so the user can reach the sink and look in the mirror - thereby the user can help take care of his own personal hygiene.

New features

- Safety and washability (IPX6W rated).
- The digital control box ensures, that if the seat is raised while tilted forwards, the Dual Security function will simultaneously tilt the seat backwards. This way, the user will not have the feeling of falling out of the chair while it is moving.
- Transport function: with one press on the hand control the chair can be put in a position used for safe transport of the user.
- The chair also comes with two memory functions which makes it quick and easy for the carer to adjust the chair in a desired position.

Product highlights

- Electrical height adjustment (Soft Start/Stop).
- Elektrical tilt (+7° / -30°) and adjustable backrest for more comfort and user stability.
- **NEW!** IPx6W rated: Can be cleaned in washing machines up to 250 times due to LINAK IPX6 Washable DURA™ (50 washes is standard).
- **NEW!** Developed from the Easy-Clean principle, which means there are no small corners or edges. The chair has closed screws/joinings and fully welded steel, which prevents water from entering the pipes. It is also treated with double coating which makes it rust resistant.
- **NEW!** Dual Security Function (it can not be raised and tilted forward simultaneously)
- **NEW!** Transport function via the hand control for safe transportation of the user.
- **NEW!** Two programmable memory buttons on the hand control for automatic positioning and adjustment.
- **NEW!** Multi adjustable headrest with integrated rod which does not scratch or damage the wall behind the toilet
- Fits over all standard toilets and suitable for use in the shower
- Max user weight 150 kg



Triton/Dual with electric lifting function and tilt (backwards -30 / forward +7 degrees)



Multi adjustable head rest



New hand control with more functions, for example two programmable memory buttons and one for safe transportation



Emergency stop and lowering

Product	Item number
Triton/Dual	044-00050
Triton/Dual with emergency stop and lowering	044-00051
Accessories	
Headrest (flexible)	047-10300
Headrest (size S)	047-10301
Swing-away torso support w. PU-padding	047-00360
PU cover for toilet seat (for factory mounted toilet seat)	047-00266
PU toilet seat with round hole	047-00271
PU cover for toilet seat with round hole	047-10317
PU toilet seat with open hygiene cut	047-00272
Soft toilet seat with smaller hole	047-00273
Anti-pressure pillow	047-00274
Wheel with direction lock (green)	047-10316
Elevating leg rest (set)	047-00606
Torso-/Hip-/Leg Belt	047-00607
Amputation leg rest: 1) Left : 047-00361 / 2) Right : 047-00362	047-00361 / 047-00362
Calf strap for footrest	047-00350
Crossbar between the armrests	047-00359
Wide arm rest (+50 mm on each side)	047-10302
Lockable armrests	Contact Winnocare
Swing-away crossbar	Contact Winnocare
PU backrest	047-10303
Plastic bedpan for factory mounted bracket set (047-00904) with lid (047-00915)	047-00904 / 047-00915
Stainless steel bedpan with lid (047-00914) / Bracket set (047-00517)	047-00914 / 047-00517
Round plastic bedpan with lid (047-00913) / Bracket set (047-10312)	047-00913 / 047-10312

TECHNICAL SPECIFICATION

Max. user weight	150 kg/330 lbs/23,62 stone	Total height	1065-1480 mm (w/o head rest)
Distance btw. arm rest	470 mm	Weight	41 kg
Seat depth	430 mm	Tilt angle	+7° til -30° +2°
Seat width	460 mm	IP class	IPX6W
Seat height	535-950 mm	Charging time	6 hours
Total width	570 mm	Battery capacity	80-100 lifting cycles
Length	880-1050 mm		

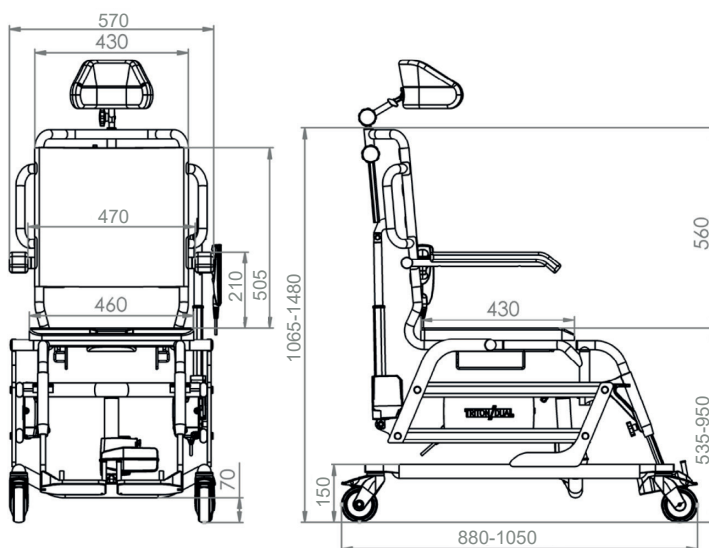

Please consult the technical manual for further specifications. All figures and measurements are for guidance only and may differ in actual situations. Winnocare Nordic reserves the right to changes without notice. Product photos may include accessories. Please consult your dealer for further information.



MDD93/42/EEC
Class I