

# Winncare **SOLAR** 185

**All purpose ergonomic mobile lift  
with 185 kg lifting capacity**



## Primary application

- Patient transfer from bed to chair or from chair to chair.
- Lift from floor, for example after a fall accident.
- Used in private homes, nursing homes and hospitals.



## Characteristics

- Change the spreader bar without any use of tools. Simply just push and twist.
- The design and shape of the lifting arm provides the user with space for a more relaxed transfer.
- The curved legs allow a wider base spread to access large chairs or wheelchairs.
- The hooks on the patented spreader bar always ensure a safe and simple sling attachment without use of finger strength; simply just pull the sling strap down to close and up to open.
- Handy hand control, which can be used with both left and right hand.



## Advantages

- High-low lift range from 680 mm to 1980 mm.
- Electrical leg adjustment with a maximum width of 920 mm (can be used with both wide chairs and wheel chairs).
- Narrow and stable chassis, which fits through doors with a width of only 700 mm.
- EASY CLEAN with smooth surfaces without contours. Easy to wipe over after use.
- Linak actuator and Lift 40+ control box with OneConnect™



The spreader bars mounted on Solar  
Can easily be tilted and turned 360°



WIN  CARE

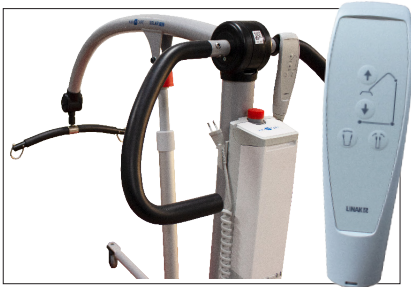

User friendly hand control and Linak control box.



LED indication on control box with information about battery and charging, service, system status (overload, emergency stop etc.).

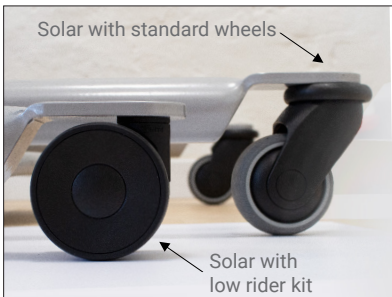

Low rider kit, which decreases the leg height by 32 mm. This is an accessory set of four wheels.



Manual emergency lowering

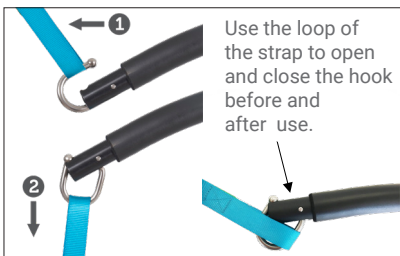

Sling attachment: a minimum of downward pressure locks the sling hook; pull upwards to unlock sling hook.

Version	Item number
WinnCare Solar 185 with 2-point spreader bar	010-01403
WinnCare Solar 185 with 3-point spreader bar	010-01404
Accessories	
2-point spreader bar, 48 cm	015-02126
3-point spreader bar	015-02106
2-point spreader bar, 48 cm with weigh scale	017-00144
3-point spreader bar with weigh scale	017-00143
Hand control	018-08269
Battery	018-08264

### TECHNICAL SPECIFICATION

Max. load (SWL)	185 kg
Lifting method	Electrical
Leg spreading method	Electrical
Emergency lowering	Manual
Emergency stop	Manual
Total weight (excl. spreader bar)	45 kg
Battery capacity	60-80 lifts (80 Kg, 0,5m)
Min. width	700 mm
Weight heaviest single part	23,8 kg

a: 1980 mm	h: 600 mm
b: 680 mm	i: 180 mm
c: 1300 mm	j: 120 mm
d: 530 mm	k: 50 mm
e: 180 mm	l: 550 mm
f: 360 mm	m: 920 mm
g: 580 mm	n: 890 mm

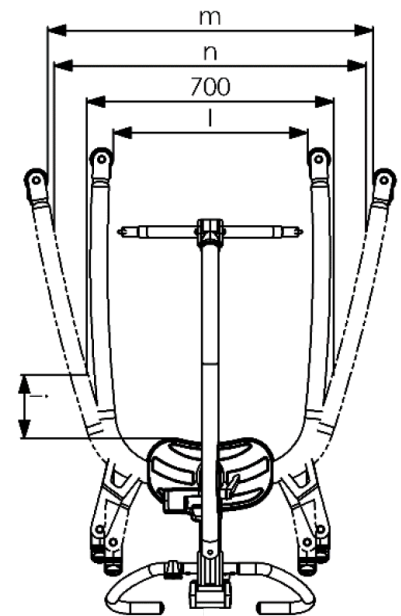
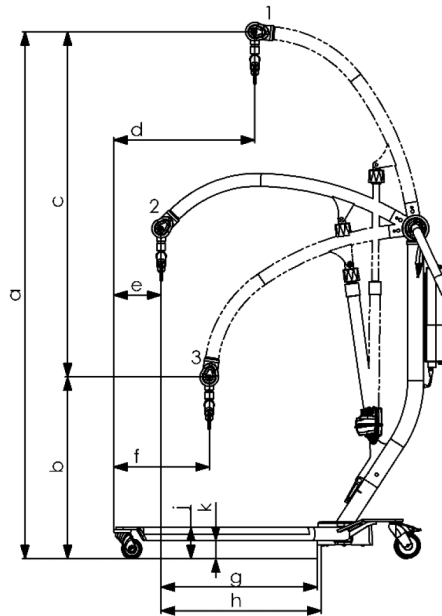

Consult the Technical manual for further specifications.  
All figures and measurements are for guidance only and may differ in actual situations.  
WinnCare Nordic reserves the right to changes without notice.  
Product photos may include accessories. Consult your dealer for more information.

