

# Winncare **STELLAR 170**

Compact mobile stand aid with 170 kg lifting capacity



## Primary application

- Transfer of users with ability to stand.
- Patient transfer from bed to chair or from chair to chair.
- Helps the user maintain the ability to stand.
- Used in private homes, nursing homes and hospitals.



## Characteristics

- The new design of the lifting arm contributes to a more comfortable lifting process and utilizes the benefits of the sling.
- The lifting arm now has 2 handles, providing a more natural grip for the user during the transfer.
- The hooks on the lifting arm always ensure a safe and simple sling attachment without use of finger strength; simply just pull the sling strap down to close and up to open.
- Knee support is easily adjusted in height and depth, providing the user with optimal support during the transfer.
- Handy hand control, which can be used with both left and right hand.
- In order to exploit the full surface, the new footplate has no contour. This way, the users can place their feet where it feels most natural to them.
- The design of the chassis provides space for the user's legs, making the transfer more safe and comfortable.
- The curved legs allow a wider base spread to access large chairs or wheelchairs.



## Advantages

- The lifting and lowering pattern is now more natural, and the user is placed correctly in the chair.
- High-low lift range from 800 mm to 1600 mm.
- Compact with a small turning radius of 1060 mm.
- Narrow and stable chassis, which fits through doors with a width of only 700 mm.
- Electrical leg adjustment with a maximum width of 920 mm (can be used with both wide chairs and wheel chairs).
- EASY CLEAN with smooth surfaces without contours. Easy to wipe over after use.
- Linak actuator and Lift 40+ control box with OneConnect™



WIN  CARE



For a more ergonomically correct and natural lifting pattern, we have redesigned the lifting arm by shortening it and adding horizontal handles on the sides.



LED indication on control box with information about battery and charging, service, system status (overload, emergency stop etc.).



Removable and redesigned footplate and adjustable knee support. Maintenance free, smooth running wheels. Rear wheels with brakes.

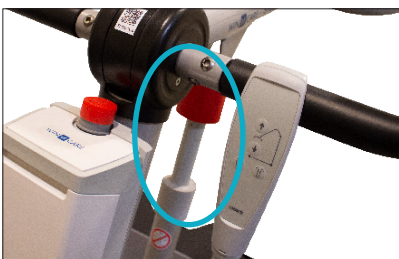

We have redesigned and moved the manual emergency lowering, which makes it easier to maneuver.

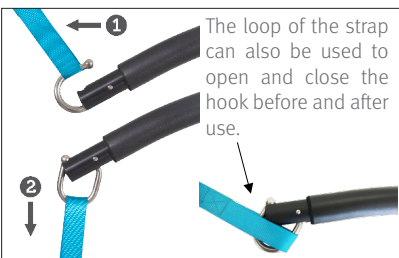

Sling attachment: a minimum of downward pressure locks the sling hook; pull upwards to unlock sling hook.

Version	Item number
WinnCare Stellar 170 stand aid	011-01701
Accessories	
Hand control	018-08269
Battery	018-08264

## TECHNICAL SPECIFICATION

Max. load (SWL)	170 kg
Lifting method	Electrical
Leg spreading method	Electrical
Emergency lowering	Manual
Emergency stop	Manual
Electrical spline	Yes
Total weight	51,4 kg
Battery capacity	60-80 lifts (80 kg, 0,5m)
Min. width	700 mm

a	1600 mm	h	390 mm
b	800 mm	i	220 mm
c	800 mm	j	120 mm
d	740 mm	k	40 mm
e	210 mm	l	540 mm
f	220 mm	m	830 mm
g	40 mm	n	770 mm

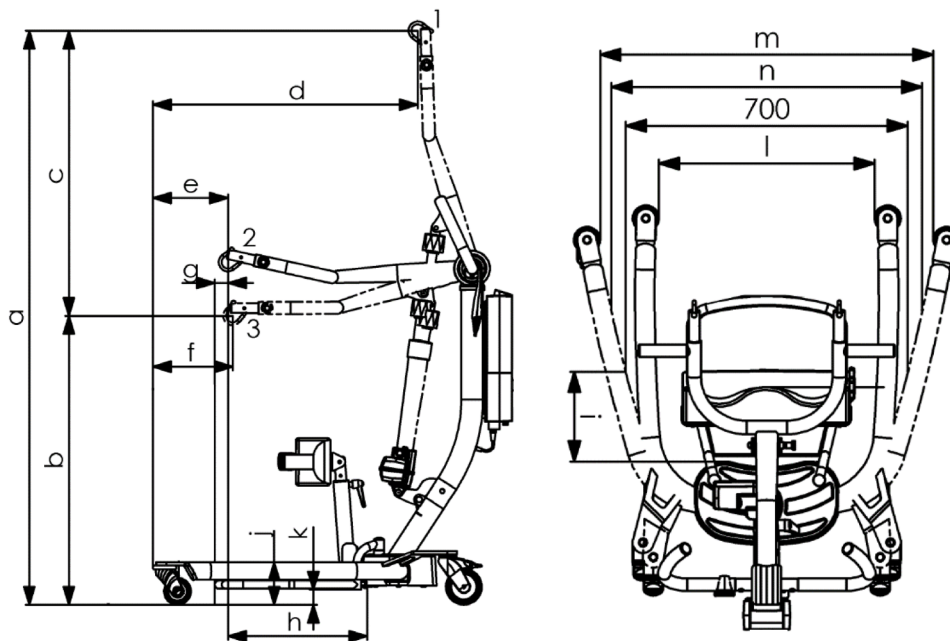

Consult the Technical manual for further specifications.  
All figures and measurements are for guidance only and may differ in actual situations.  
WinnCare Nordic reserves the right to changes without notice.  
Product photos may include accessories. Consult your dealer for more information.



date 10.12.2021- ver. 1

WinnCare Nordic ApS  
Taarnborgvej 12C  
4220 Korsoer  
Tlf.: +45 70 27 37 20  
E-mail: info@winnCare.dk

[www.winnCare.dk](http://www.winnCare.dk)

