

NEW

# Luna Mover

## Motorised Ceiling Cassette

Ergolet's innovative Luna ceiling hoist, with its unique Scandinavian design and excellent functionality, now has a brand new companion - The Luna Mover.

The Luna Mover allows the caregiver to effortlessly power the Luna ceiling lift horizontally along the track by use of the hand control, regardless of the patient's weight or the size of caregiver.

The Luna Mover is also helpful in situations where the caregiver wants to stop the Luna ceiling lift at a specific point or if the caregiver, for some reason, needs powered assistance to move the patient along the track.

In a home care environment Luna Mover also gives users the benefit of increased independence. If a user can put on the sling independently they can then, via the hand control functions, transfer themselves, e.g. from bed to bathroom.

The Luna Mover is powered and controlled by the Luna ceiling lift, which means no extra charging cables. Simply connect the two units with the supplied cable. It is also fitted with a patent pending safety system which, if needed, can be unlocked by using the integrated safety release handle. After unlocking, the Luna Mover can be then manually moved along the track.

The Luna Mover from Ergolet is manufactured to meet the same high standard of functionality and design as our classic Luna IPx4, and therefore carries Ergolet's unique 5-year warranty.

### PRODUCT FEATURES AND HIGHLIGHTS

- SWL (Safe Working Load) 275 kg
- Move function in comfortable walking speed
- Patent pending safety system
- Fits onto 75 mm and 135 mm tracks
- Soft start and stop function
- Increased independence for residential users
- IPx4 safe for bathroom areas

 ergolet®

by Winncare Nordic



Luna Mover mounted on the Mobile Flex

Version	Item-number
Luna Mover	016-02500

Accessories	
Luna 2ch. 200 kg.	015-03032
Luna 2ch. 275 kg.	015-03034



The integrated safety release handle allows manual transfer if needed

## TECHNICAL SPECIFICATION

Luna Mover	
	Measurements
A	270 mm
B	125 mm
C	260 mm



Easy mounting of the Luna



The familiar hand control with arrows indicating transfer direction

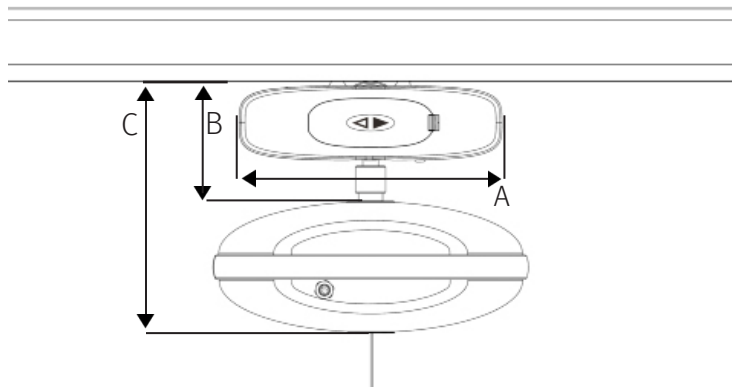

Consult the user manual for further specifications. All figures and measurements are for guidance only and may differ in actual situations. Winnicare Nordic ApS reserves the right to changes without notice.

Product photos may include accessories. Consult your dealer.



date 11.10.2017 - ver.3

Winnicare Nordic ApS  
 Taarnborgvej 12C  
 4220 Korsoer  
 Denmark  
 tel. +45 70 27 37 20  
 e-mail: info@winnicare.dk

[www.winnicare.dk](http://www.winnicare.dk)

**WINN**CARE  
 Nordic